

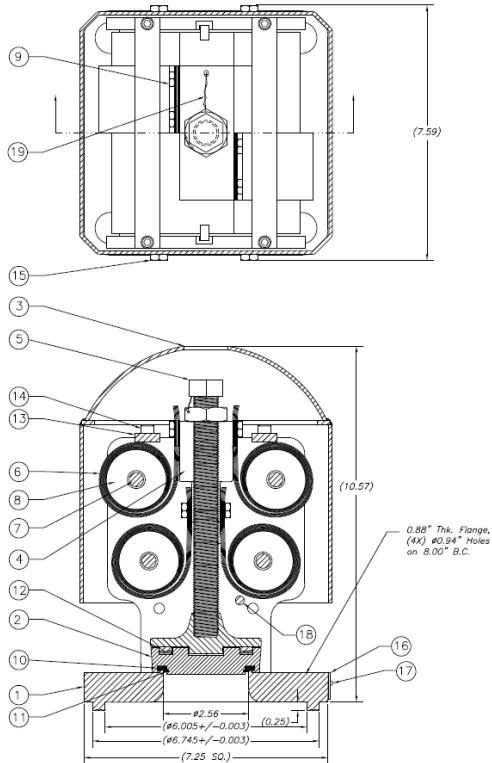

# Pressure Relief Valve PC280.5HS



| Valve Model            | PC280.5HS       |
|------------------------|-----------------|
| Set Pressure (psig)    | 280.5           |
| Orifice Diameter (in)  | 2.56            |
| Flow Area (sq. in)     | 5.14            |
| Weight (lbs.)          | 43              |
| Flow Rate @ 308.5 psig | 23,396 SCFM     |
| Height (in)            | 10.82           |
| Flange Thickness (in)  | 0.875           |
| Number of Bolt Holes   | 4               |
| Bolt Hole Size (in)    | 0.94            |
| Bolt Circle (in)       | 8.00            |
| Interface Options      | Tongue & Groove |
| Number of Springs      | 53              |

|        |      |                           | PC280.5HS                |
|--------|------|---------------------------|--------------------------|
|        |      |                           | PRD172102                |
| ITEM # | QTY. | DESCRIPTION               | MATERIAL                 |
| 1      | 1    | Body Assembly             | Stainless Steel – 316L   |
| 2      | 1    | Sealing Disc              | Stainless Steel          |
| 3      | 1    | Cover                     | Carbon Steel             |
| 4      | 1    | Spring Block Assembly     | Stainless Steel          |
| 5      | 1    | Adjustment Screw Assembly | Stainless Steel - 416    |
| 6      | 8    | Spring Drum Assembly      | Stainless Steel          |
| 7      | 4    | Drum Bolt                 | Stainless Steel          |
| 8      | 4    | Spring Drum               | Nylon 6/6                |
| 9      | 16   | Spring Bolt               | Stainless Steel          |
| 10     | 1    | Seal*                     | Elastomer                |
| 11     | 1    | Spirolox Ring             | Stainless Steel          |
| 12     | 1    | Needle Bearing            | Hardened Steel           |
| 13     | 2    | Spring Bracket Brace      | Stainless Steel          |
| 14     | 4    | Brace Bolt                | Stainless Steel          |
| 15     | 4    | Cover Bolt                | Carbon Steel/Zinc Plated |
| 16     | 1    | Name Plate                | Aluminum                 |
| 17     | 2    | Nameplate Rivet           | Stainless Steel          |
| 18     | 1    | Lift Stop                 | Stainless Steel          |
| 19     | 1    | Wire/Seal                 | Stainless Steel/Lead     |

\*Under Service Trial – ST 468

Patent#: US 9,568,146

Seal material composition based on specification

Other Sealing options available

Note: Mounting flange gasket not supplied

\*Alternate Materials Available

© 2017 Kelso Technologies (USA) Inc. All Kelso Vacuum Relief Valves Patent Protected. Detailed designs are subject to change without notice, detailed drawings available upon request.  
Kelso Technologies Inc. 1526 Texas Ave, Bonham, Texas 75418, Phone: (903) 583-9200

Document No. - KTUD033  
Revision 1 – 10/11/2017 (Original Release 4/11/2017)

www.kelsotech.com

Printed in U.S.A.